

NOTE: This is an installation *supplement*. Please refer to the original IOM for all applicable products before using this document.



RECTANGULAR BREAKAWAY STYLE TRANSVERSE JOINTS

Transverse joints illustrated in Figure 2 to the right have always been approved as breakaway connections. SMACNA testing has also approved the following variations as breakaway connections.

1. All joints in Figure 2 can be applied with #10 sheet metal screws (through joint and duct) subject to the following limitations: maximum 2 screws in each side and in bottom joint.
2. Transverse joints illustrated can be applied as top and bottom joints with Drive Slip shown in Figure 3 - side joints in duct heights up to 20 inches (508mm).

ROUND & OVAL DUCT BREAKAWAY CONNECTIONS

Round or flat oval ducts connected to Type R, CR or CO damper collars shall be #10 sheet metal screws as follows:

1. Ducts to 22" (558mm) wide (or diameter) and smaller may use 3 screws.
2. Ducts larger than 22" (558mm) wide (or diameter) and up to 36" (914mm) wide (or diameter) may use 5 screws.
3. Ducts larger than 36" (914mm) wide (or diameter) may use 8 screws.

NOTE: When optional sealing of these joints is desired, the following sealants may be applied in accordance with the sealant manufacturer's instructions: Design Polymerics - DP1010.

**MANUFACTURED FLANGED SYSTEM
BREAKAWAY CONNECTIONS:**

Flanged connection systems manufactured by Ductmate, Ward and Nexus are approved as breakaway connections when installed as illustrated in Figure 3.

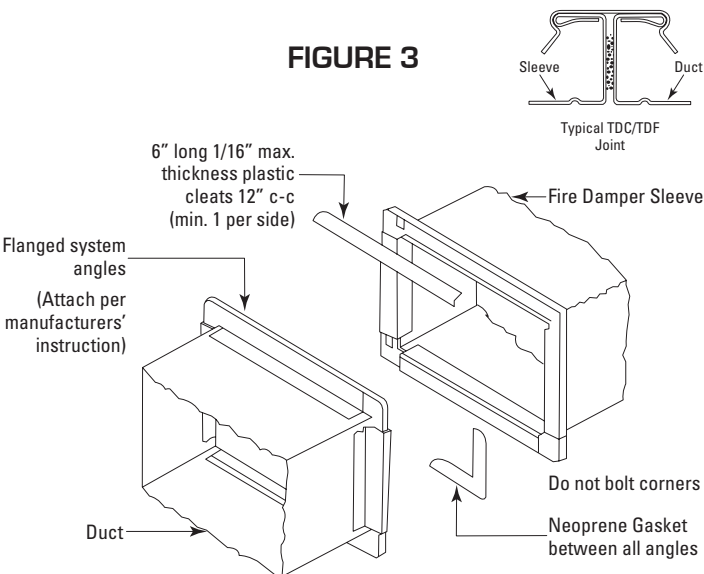

FIGURE 3

**PROPRIETARY FLANGE SYSTEM
BREAKAWAY CONNECTIONS:**

TDC and TDF systems are approved as breakaway connections when installed as described in the TDC or TDF addendum to the SMACNA Duct Constructions Standards.

Standard 6" (152 mm) metal clip may be used with spacing as shown in Figure 4. Three-eighths inch (10mm) metal bolts and nuts may be used to fasten together corner places.

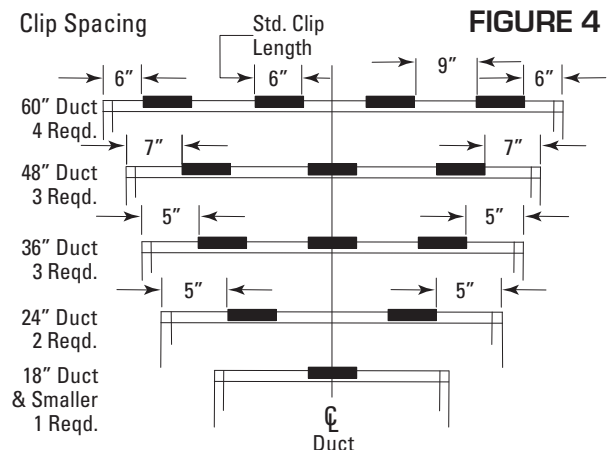

FIGURE 4

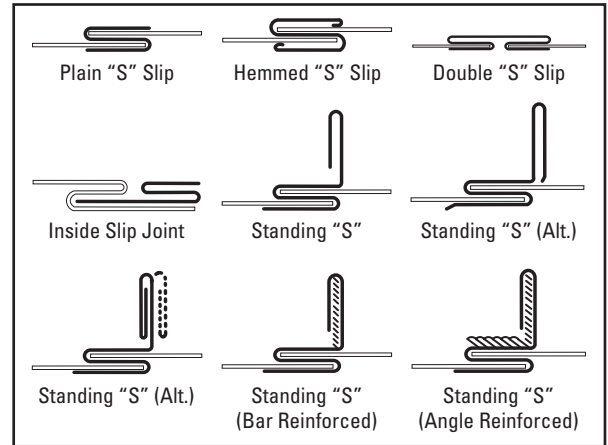

FIGURE 1



FIGURE 2

CONNECTIONS OF DISSIMILAR PROPRIETARY FLANGE SYSTEMS:

These instructions are for CVS-SAFE4 fire and combination fire/smoke damper connections. They apply to the connection between a manufactured flange system by Ward, Duct-mate, Nexus, TDC and TDF. These connections allow the combining of mixed flange types or like for like. These instructions may be used with 20 ga. damper sleeves connecting to 20 ga. and lighter ducts.

The following instruction depicts the use of metal or plastic cleats, butyl or neoprene gasket, and bolted or non-bolted corners. The flanges may also be connected using #10 screws without cleats.

1. Install the manufactured flange system onto the damper sleeve or duct per the manufacturer's installation instructions.
2. Seal the two flange systems together. Neoprene or Butyl gasket may be applied to the mating surfaces.
3. Align the two flange systems together. A 3/8" (9mm) bolt may be used in the corners to help with the alignment. The bolt does not have to be removed. Bolted corners are permitted.
4. Install the cleat or #10 tek screw, approximately equally spaced, per Table 1.

TABLE 1

CLEATS/SCREWS PER SIDE OF BREAKAWAY CONNECTIONS

WIDTH or HEIGHT	# OF CLEATS OR SCREWS PER SIDE
Less than 24" (610)	1
24" (610) to less than 36" (914)	2
36" (914) to less than 54" (1372)	3
54" (1372) to less than 72" (1829)	4
72" (1829) or greater	5

All measurements in () parentheses are in millimeters.

