



**Industrial Airfoil Blade Control Damper  
Model NAH-720-4**

**Design / Application**

Model **NAH-720-4** (Opposed Blade Operation) and **NAH-721-4** (Parallel Blade Operation) are Industrial Air Control Damper with Airfoil Shaped Blades. These models consist of a heavy duty flanged frames designed for direct attachment to the ductwork or equipment. **NAH Series** models are ideal for balancing and/or shut off HVAC applications in the industrial systems with many options to meet your needs.

**STANDARD CONSTRUCTION:**

**FRAME:**

8" x 2-1/2" x 3/8" H.R.S. channel

**BLADES:**

Airfoil-shaped 12 ga H.R.S. double skin construction 5" to 8" wide.

**AXLES:**

Plated steel 1-7/16"Ø T.G.&P

**LINKAGE:**

9 ga galvanized jamb linkage

**BEARINGS:**

Cast iron housing 2 hole ball bearings

**FINISH:**

Powder Coated (super durable polyester gray)

**SIZE LIMITATIONS:**

Maximum size: 60"w x 96"h  
Minimum size: single blade 6"w x 8"h

**RATINGS:**

Pressure: 10-40" w.g.- differential pressure

Velocity: 3000-8000 fpm

Temperature: -20°F - 1,000°F (without blade gasket)

**Note: Special blade clearances are required when temperatures exceed 250°F (121°C).**

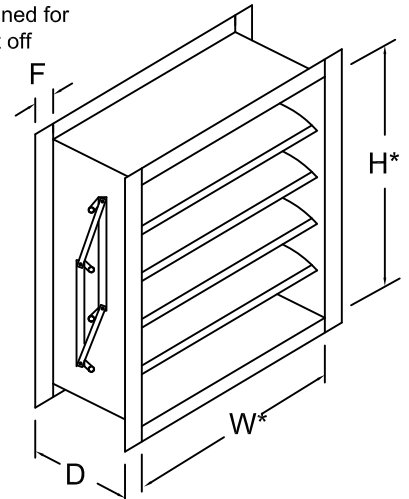
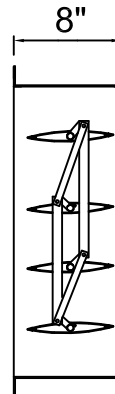

**NOTE:** Damper blades always run horizontal and are always the first dimension (W) when ordering (example: always order W" x H").

**\*Inside Dimensions are Actual Size(not undersized)**



**OPTIONS**

- Stainless steel jamb seals
- Flange bolt holes
- EPDM blade seals 250° F
- Silicone blade seals 450° F
- 304 stainless steel construction
- 316 stainless steel construction
- Bearing Options: (consult factory)
  - Wheel driven worm gear heavy duty
  - Chain driven worm gear heavy duty
- Stuffing box seal
- Outboard bearing with shaft seal
- Linkage cover
- Central manifold grease system
- Actuator
- Powder Coated
- 1000° F (powder coated) resistance
- Insulated (Foam Filled Blades)

Quantity:	Max. Temp. (if higher than 250°F)	"W" Width	"H" Height	Frame Depth "D" 8" std.	Flange Width "F" 2" std.	Bolt Hole Information							REMARKS	
						J	N1	L Spacing	M Dia.	K	N2	C		

Job Name:	<input type="checkbox"/> <b>Model NAH-720-4</b> (opposed blades) <input type="checkbox"/> <b>Model NAH-721-4</b> (parallel blades)
Location:	
Architect:	
Engineer:	
Contractor:	

# MODEL NAH-720-4 PERFORMANCE DATA

## Imperial Units (Forward Flow)

Damper Width X Height	1 in. w.g. Class	4 in. w.g. Class	8 in. wg Class	*Torque (per sq. ft.)
12" x 12"	Class I	Class I	Class I	18 lbs-in
24" X 24"	Class I	Class I	Class I	15 lbs-in
36" X 36"	Class I	Class I	Class I	18 lbs-in
12" X 48"	Class I	Class I	Class I	15 lbs-in
48" X 12"	Class I	Class I	Class I	15 lbs-in
60" X 36"	Class I	Class I	Class I	18 lbs-in

Air leakage is based on operation between 50°F to 104°F. All data corrected to represent air density of 0.075 lbs/ft.<sup>3</sup>

\*Torque applied to hold damper in closed position

## Imperial Units (Back Flow)

Damper Width X Height	1 in. w.g. Class	4 in. w.g. Class	8 in. wg Class	*Torque (per sq. ft.)
12" x 12"	Class I	Class I	Class I	18 lbs-in
24" X 24"	Class I	Class I	Class I	15 lbs-in
36" X 36"	Class I	Class I	Class I	18 lbs-in
12" X 48"	Class II	Class II	Class II	15 lbs-in
48" X 12"	Class I	Class I	Class I	15 lbs-in
60" X 36"	Class I	Class II	Class I	18 lbs-in

\*Torque applied to hold damper in closed position

		Leakage, ft <sup>3</sup> /min <sup>2</sup> /ft			
		Required Rating		Extended Ranges (optional)	
Class	Pressure	1"	4"	8"	12"
	I		4	8	11
II		10	20	28	35
III		40	80	112	140

All data corrected to represent standard air at a density of 0.075 lbs/ft.

NAH-720 SOUND RATINGS								
Damper Size	Damper Full Open		Damper 75% Open		Damper 50% Open		Damper 25% Open	
	CFM	NC	CFM	NC	CFM	NC	CFM	NC
12 x 12	2000	16	1500	11	1000	11	500	*
	3000	28	2250	21	1500	18	750	*
	4000	36	3000	29	2000	24	1000	*
18 x 18	2250	17	1688	10	1125	21	563	*
	4500	33	3375	26	2250	31	1125	*
	6750	43	5063	37	3375	40	1688	15
24 x 24	4000	11	3000	10	2000	26	1000	*
	8000	33	6000	29	4000	37	2000	21
	12000	43	9000	42	6000	46	3000	31

NC = Noise criteria in Decibels is based on room effect and 10db of room attenuation.  
\* = Less than 10 NC

## AMCA Test Figures

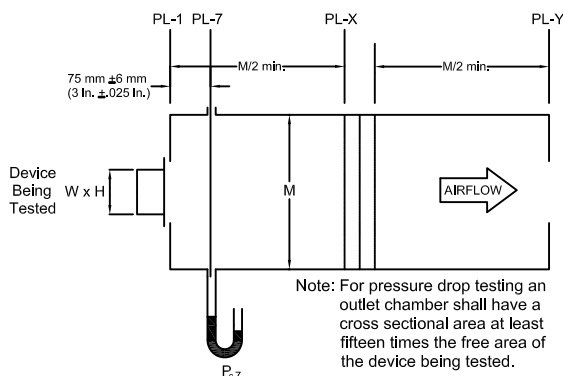

Figure 5.4- Test Device Setup with Outlet Chamber

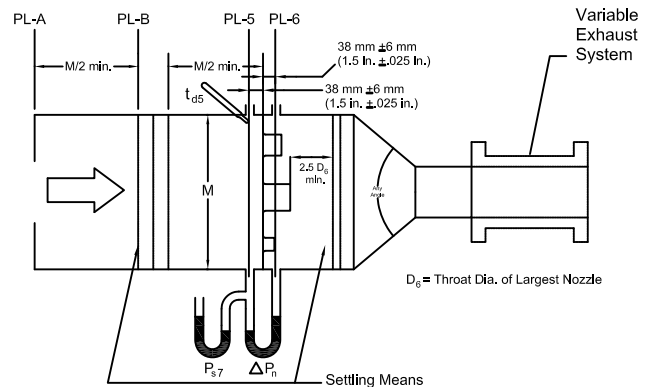

Figure 6.3- Airflow Rate Measurement Setup- Multiple Nozzle Chamber on Fan Inlet

# MODEL NAH-720-4 PERFORMANCE DATA

## Standard International Units (Forward Flow)

Damper Width X Height (mm)	250 Pa Class	1 KPa Class	2 KPa Class	*Torque
305 x 305	Class I	Class I	Class I	3,214 grams-cm
610 X 610	Class I	Class I	Class I	2,679 grams-cm
915 X 915	Class I	Class I	Class I	3,214 grams-cm
305 X 1220	Class I	Class I	Class I	2,679 grams-cm
1220 X 305	Class I	Class I	Class I	2,679 grams-cm
1525 X 915	Class I	Class I	Class I	3,214 grams-cm

Air leakage is based on operation between 10°C to 40°C. All data corrected to represent air density of 1.201 kg/m<sup>3</sup>.

\*Torque applied to hold damper in closed position

## Standard International Units (Back Flow)

Damper Width X Height (mm)	250 Pa Class	1 KPa Class	2 KPa Class	*Torque
305 x 305	Class I	Class I	Class I	3,214 grams-cm
610 X 610	Class I	Class I	Class I	2,679 grams-cm
915 X 915	Class I	Class I	Class I	3,214 grams-cm
305 X 1220	Class II	Class II	Class II	2,679 grams-cm
1220 X 305	Class I	Class I	Class I	2,679 grams-cm
1525 X 915	Class I	Class II	Class I	3,214 grams-cm

\*Torque applied to hold damper in closed position

		Leakage, L/s /m <sup>2</sup>			
		Required Rating		Extended Ranges (optional)	
Class	Pressure	0.25 kPa	1.0 kPa	2.0 kPa	3.0 kPa
I		20.3	40.6	55.9	71.1
II		50.8	102	142	178
III		203	406	569	711

## FRAME CONSTRUCTION OPTIONS

Flange (F Dim): Standard- 2"  
Optional - 1-1/2" to 4"

Bolt holes: (Standard construction is **no** bolt holes)

Dim. "M": 7/16" dia. hole  
Dim. "L": 6" Center to Center

Web (D Dim): Standard - 8"  
Optional - 8" to 12"

**Note:** Customer must be within Min. or Max limits on table below.

Dim.	Min or Max	Standard	Description
<b>J</b>	min. 3/4"		First/Last Space in <u>Head/Sill</u>
<b>N1</b>	min. 1.0"		No. of holes in <u>Head/Sill</u>
<b>K</b>	min. F/2"		First/Last Space in <u>Jamb</u>
<b>N2</b>	min. 1.0"		No. of holes in <u>Jamb</u>
<b>C</b>	.75*D" to 3/4"	F/(2*M)"	Centerline of bolt hole from inside edge of frame
<b>L</b>	2" to 12"	6.0"	Hole Spacing
<b>M</b>	1/4" to 11/16"	7/16"	Mounting hole Diameter

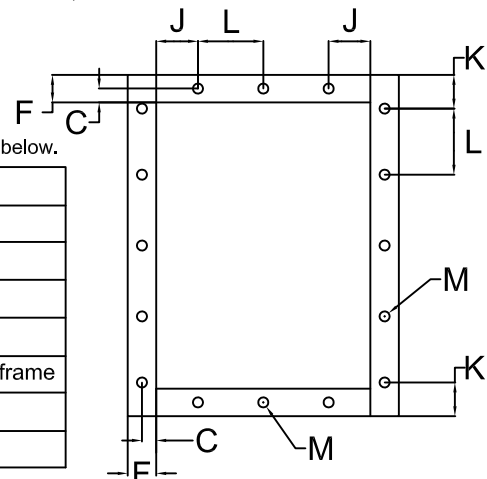

# MODEL NAH-720-4 PERFORMANCE DATA

## PRESSURE DROP

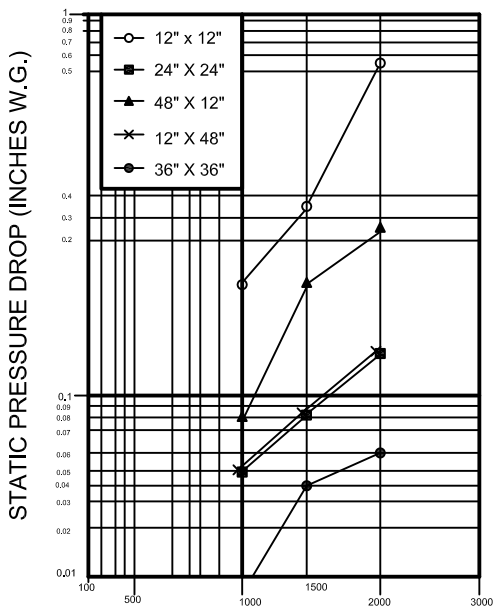

### Face Velocity (FT/MIN)

Based on STANDARD AIR- .075 lb. per cubic foot.

NAH-720-4 sizes: 12x12, 24x24, 48x12, 12x48, 36x36  
(305x305, 610x610, 1219x305, 305x1219, 914x914)

### NAH-720-4

#### PRESSURE LIMITATIONS

The chart at the right shows conservative pressure limitations based on a maximum blade deflection of  $w/360$ .

#### TEMPERATURE LIMITATIONS

Blade Seals: EPDM  $-40^{\circ}$  to  $+250^{\circ}$ F  
Silicone Rubber  $-40^{\circ}$  to  $+450^{\circ}$ F  
Jamb Seals: Flexible stainless steel  $-40^{\circ}$  to  $+400^{\circ}$ F

#### VELOCITY LIMITATIONS

The chart at the right shows conservative velocity limitations based on damper size.

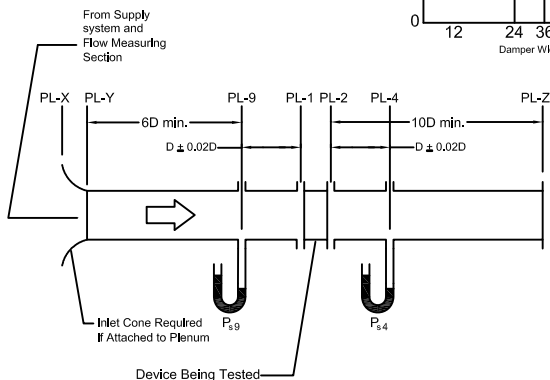
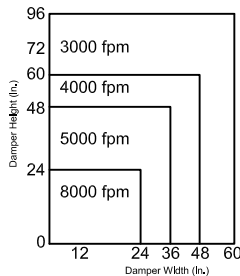
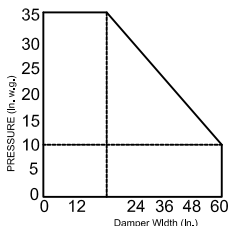

Figure 5.3- Test Device Setup with Inlet and Outlet Ducts

### AMCA Test Figure 5.3

Figure 5.3 illustrates a fully ducted damper. This configuration has low pressure drop because entrance and exit losses are minimized by straight duct runs upstream and downstream of the damper.

### Pressure Drop Data

This pressure drop data was conducted in accordance with AMCA Standard 500 using Test Figure 5.3. All data has been corrected to represent standard air at a density of .075 lb/cu.ft.

Actual pressure drop found in any HVAC system is a combination of many factors. This pressure drop information along with an analysis of other system influences should be used to estimate actual pressure losses for a damper installed in a given HVAC system.

#### 12 x 12

Face Velocity ft/min (m/s)	Pressure Drop in. w.g. (Pa)
1000 (5.08)	0.18 (45)
1500 (7.62)	0.35 (88)
2000 (10.16)	0.57 (144)

#### 24 x 24

Face Velocity ft/min (m/s)	Pressure Drop in. w.g. (Pa)
1000 (5.08)	0.05 (12)
1500 (7.62)	0.08 (20)
2000 (10.16)	0.13 (33)

#### 48 x 12

Face Velocity ft/min (m/s)	Pressure Drop in. w.g. (Pa)
1000 (5.08)	0.08 (20)
1500 (7.62)	0.18 (45)
2000 (10.16)	0.26 (66)

#### 12 x 48

Face Velocity ft/min (m/s)	Pressure Drop in. w.g. (Pa)
1000 (5.08)	0.05 (12)
1500 (7.62)	0.08 (20)
2000 (10.16)	0.13 (33)

#### 36 x 36

Face Velocity ft/min (m/s)	Pressure Drop in. w.g. (Pa)
1000 (5.08)	0.011 (3)
1500 (7.62)	0.04 (10)
2000 (10.16)	0.06 (15)

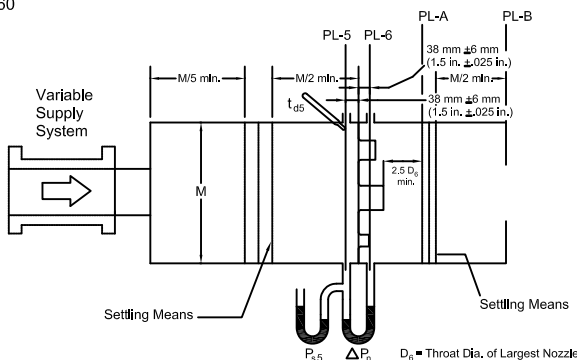

Figure 6.5- Airflow Rate Measurement Setup- Multiple Nozzle Chamber on Fan Outlet