

Reference:

Client:

Project:

Consultant:

Location:

Contractor:

Date:

Submitted by:



Manufacturing Excellence

Model FSD-AF-OW-211

Combination Fire/Smoke Damper
Out-of-Wall/Floor Application

Airfoil Blade, 1-1/2 Hour, Class 1, UL-Classified

(Class 1 is < 8 cfm per sq. ft. @ 4" w.g.)

Application:

The CVS-SAFE4 model FSD-AF-OW-211 is a combination fire/smoke damper with Airfoil style blades, for decreased pressure drop, intended for installation outside the plane of a wall or floor. The FSD-AF-OW-211 is used to prevent the spread of fire and smoke through a penetration in a fire and smoke rated barrier made by an HVAC duct or transfer. The FSD-AF-OW-211 can be installed vertically (with blades running horizontally) or horizontally. The FSD-AF-OW-211 can be installed in static or dynamic systems up to the allowable tested pressures and velocities below.

MAXIMUM VELOCITY: 2000 fpm (10.2 m/s).

MAXIMUM PRESSURE: 4" wg (1kPa).

Standard Construction:

	Standard	Optional
Frame Material	20 Gauge (1) Galv. Roll-Formed Steel hat section w/ staked corners for integral bracing	-----
Blade Material and Type	Airfoil-shaped, double skin galvanized steel mechanically fastened to form equivalent to 14 Gauge (2) Steel	16 Gauge (1.5) "3V" Galvanized Roll-Formed Steel (see Model FSD-3V-OW-211)
Blade Sizes	Min. width of 5" (127) to max. width of 7.25" (178)	-----
Frame Depth	5" (127)	-----
Dimensions	Actual - 1/4" (6)	Actual
Axle Bearings	Bronze Oilite (press fit into frame)	-----
Axle Material	Plated Steel	-----
Linkage	.125" (3.2) plated steel, Concealed in Frame	-----
Sleeve	16" x 20" gauge (406x1) galvanized steel	Wide variety of gauges and lengths available
Thermal Blanket	0.25" (6) thick thermal blanket 3 sides for vertical & 4 sides for horizontal applications	-----
Heat Responsive Device	Electric thermostat (165°F - 74°C)	212°F (100°C) 250°F (121°C) 350°F (177°C)
Operating Temp.	350° (177°C)	-----
Leakage Class Rating	Class 1	Class 2 (see Model FSD-AF-OW-212)
UL Hour Rating	1-1/2 Hour	-----

Minimum & Maximum Sizes:

Out-of-Wall Mounting	Minimum Single Section	Maximum Single Section	Maximum Multi-Section
FSD-AF-OW-211 Vertical	8 x 8 (203 x 203)	36" x 48" (914 x 1219)	42" x 48" (1067 x 1219)
FSD-AF-OW-211 Horizontal			

All dimensions shown in inches, parentheses () indicate millimeters.

1 As part of our continuous improvement program, we reserve the right to make further improvements without notice.



SEE COMPLETE MARKING ON PRODUCT

LISTINGS:

UL Listing: R27700(UAE), R41135(KSA), R40068(Qatar), R41122(Egypt)

STANDARDS MET:

NFPA Standards: 80, 90A, 92A, 92B and 101

Building Code Standard:

ICC International Building Code

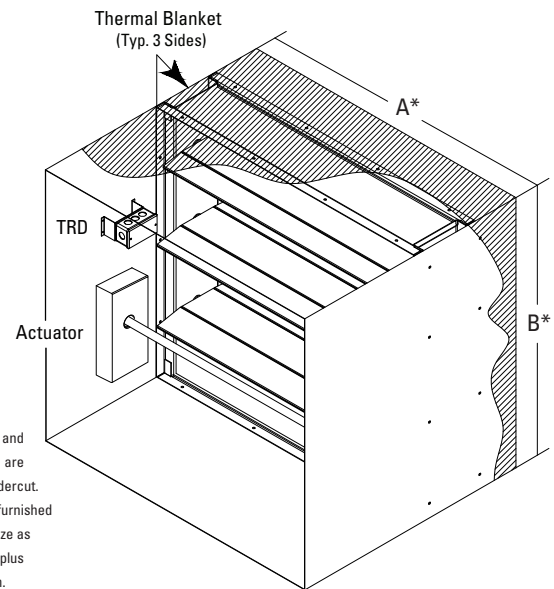

*Width [A dimension] and *Height [B Dimension] are approximately 1/4" undercut. Sleeved dampers are furnished approximately same size as given duct dimension plus 0.25" (6) for insulation.

Optional Construction:

Auxiliary Switch

Add to Actuator (recommended) Add to Damper (STO/R)

Momentary Test Switch

DTO/R Dual Thermostat Override w/ Dual Position Indicator Switches

Temp: 165°/250° 165°/350° 212°/350°

Factory Sleeve:

Length: _____ (Std. 16" [406])

Gauge: 20 (1.0) 18 (1.2) 16 (1.5) 14 (2.0) 10 (3.5)

Framed Retaining Angles (FRA)

1-Side 2-Sides

Remote Control Box

RCB-1 RCB-2 RCB-3

Smoke Detector

Factory Mounted Shipped Loose

Actuators (Refer to UL Damper Actuator Reference Chart)

Type: Electric: Model # _____ Pneumatic: Model # _____

Location: Right External (Std) Left External Internal

Submittal

Pressure Drop

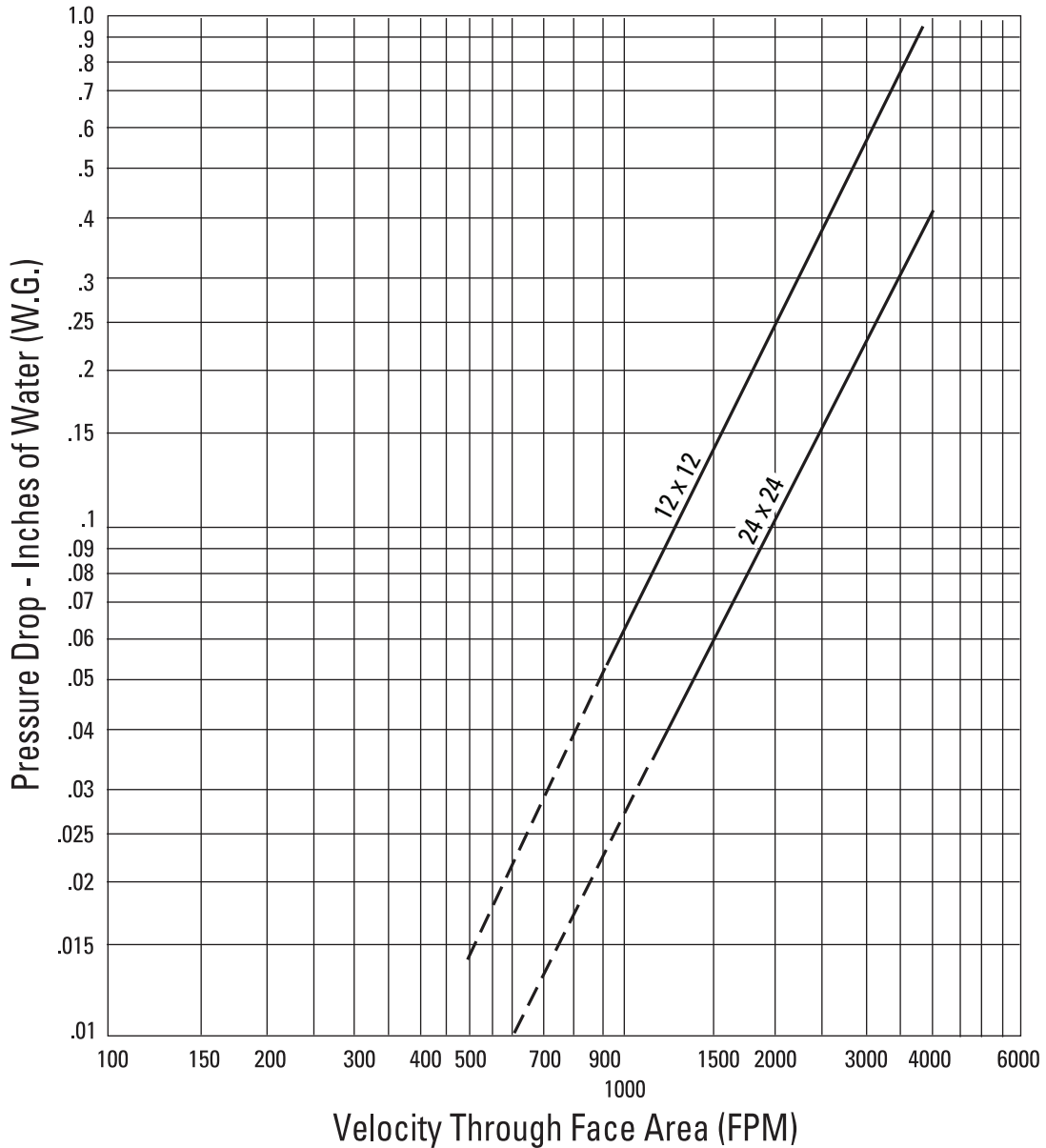

- To determine pressure drop:**
1. Locate the applicable face velocity on the bottom of the chart.
 2. Move up the chart to the most appropriate size damper line.
 3. From the intersection point, move left to determine the pressure drop.

AMCA Figure 5.3 - Ducted Inlet and Outlet

Pressure drop testing was performed by an independent laboratory to the AMCA Standard 500-D, Fig. 5.3 (ductwork upstream and downstream).

Note:

Pressure Drop data reflects damper face area only and does not take into account internally mounted actuator.

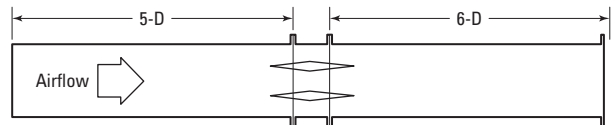

Actuator Requirements:

UL555S requires that all leakage rated dampers be provided with factory mounted actuators. Available actuators vary by damper size and velocity, pressure and temperature ratings. Consult Motor/Actuator sheet for UL Products for current offering.

All electric actuators will be factory wired to a single heat-responsive device. *The default heat-responsive device is a resettable thermostat that interrupts power to the actuator allowing for controlled closure.*

If pneumatic actuators are employed, all will be plumbed to a common PFV (Pneumatic Fusible Valve). The PFV is used in conjunction with a restrictor valve to also provide controlled closure.

Sleeve Requirements:

Sleeve must be installed at the factory for out of wall/floor products. As with all fire rated damper installations, the sleeve must fully penetrate the wall/floor being protected.

Sleeve length is dependent upon damper height, grille depth (including OBD) and actuator selection:

- Standard clearance allowance for grille inset is 3" (76).
- Maximum sleeve length is 16"(406) plus the total wall depth.

Sleeve is provided with a 3/4" (19) flange on the actuator end of the sleeve by default. Flange must be on top of barrier in horizontal installations. Damper may be optionally ordered without flange for continuous duct installation; this method requires the use of a single mounting angle for installation (see Detail).

Thermal Blanket:

A factory installed thermal blanket is provided on three sides (bottom excluded) for dampers ordered for vertical installation and on all four sides for dampers ordered for horizontal installation.

Due to the nature of the application for Out-of-Wall and Out-of-Floor Combination Fire/Smoke dampers, a 0.25" (6) thermal blanket is installed around the sleeve at the factory.

This insulation is required as part of the UL Listing of the out of wall/out of floor assembly and must not be removed.

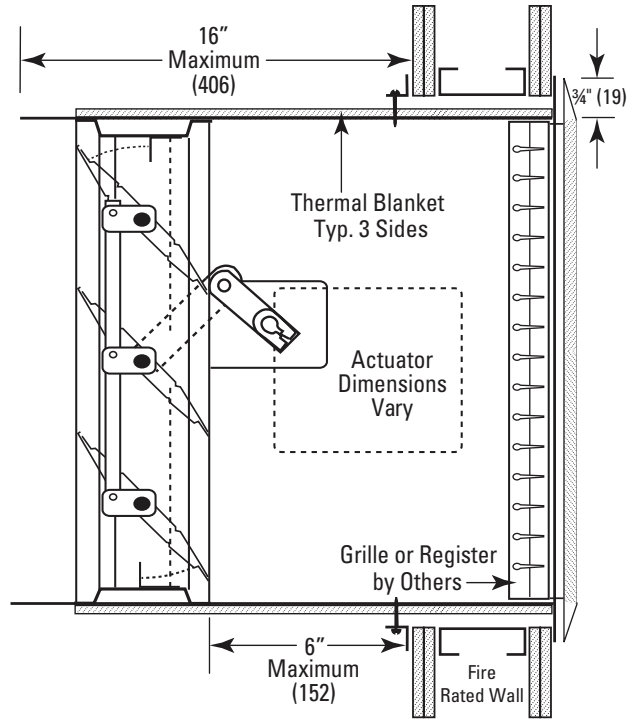

*Thermal Blanket provided 3 sides for Vertical and 4 sides for Horizontal.

