

Reference:

Client:

Project:

Consultant:

Location:

Contractor:

Date:

Submitted by:



Manufacturing Excellence

Model FSD-3V-212

Combination Fire/Smoke Damper
3V Blade, 1-1/2 Hour, Class 2, UL-Classified

(Class II is < 20 cfm per sq. ft. @ 4" w.g.)

Application:

The CVS-SAFE4 model FSD-3V-212 is a combination fire/smoke damper with 3V style blades. The FSD-3V-212 is used to prevent the spread of fire and smoke through a penetration in a fire and smoke rated barrier made by an HVAC duct or transfer. The FSD-3V-212 can be installed vertically (with blades running horizontally) or horizontally. The FSD-3V-212 can be installed in static or dynamic systems up to the allowable tested pressures and velocities below.

MAXIMUM VELOCITY: 2000 fpm (10.2 m/s) on all sizes.

MAXIMUM PRESSURE: 4" wg (1kPa) on all sizes.

Standard Construction:

	Standard	Optional
Frame Material	20 Gauge (1) Galv. Roll-Formed Steel hat section w/ staked corners for integral bracing	-----
Blade Material and Type	16 Gauge (1.5) "3V" Galv. Roll-Formed Steel	Airfoil Galv. Steel (see Model FSD-AF-212)
Blade Sizes	Min. width of 4.25" (108) to max. width of 7.25" (184)	-----
Frame Depth	5" (127)	-----
Dimensions	Actual - 1/4" (6)	Actual
Axle Bearings	Bronze Oilite (press fit into frame)	-----
Axle Material	Plated Steel	-----
Linkage	.125" (3.2) plated steel, Concealed in Frame	-----
Sleeve	16" x 20 gauge (406x1) galvanized steel	Wide variety of gauges and lengths available
Heat Responsive Device	Electric thermostat 165°F (74°C)	212°F (100°C) 250°F (121°C) 350°F (177°C)
Operating Temp.	350° (177°C)	-----
Leakage Class Rating	Class 2	Class 1 (see Model FSD-3V-211)
UL Hour Rating	1-1/2 Hour	3 Hour (see Model FSD-3V-232)

Minimum & Maximum Sizes:

Mounting	Minimum Single Section	Maximum Single Section	Max. Multiple Section Assembly
FSD-3V-212 Vertical	6" w x 6" h* (152 x 152)	36" w x 48" h (914 x 1219)	108" w x 96" (2743 x 2438)
FSD-3V-212 Horizontal			72" w x 96" (1829 x 2438)

All dimensions shown in inches, parentheses () indicate millimeters.



LISTINGS:

UL Listing: R27700(UAE), R41135(KSA), R40068(Qatar), R41122(Egypt)



STANDARDS MET:

NFPA Standards: 80, 90A, 92A, 92B and 101

Building Code Standard:

ICC International Building Code

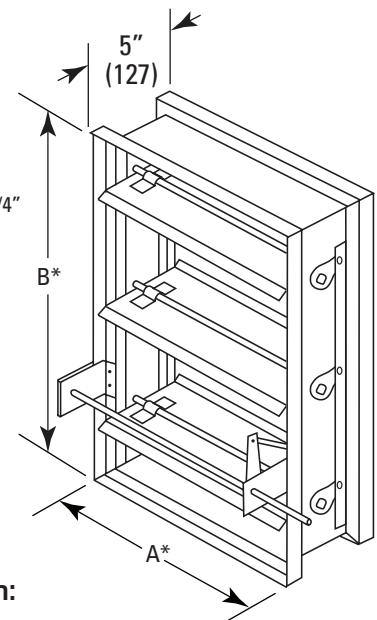

* Width [A dimension] and Height [B dimension] are approximately 1/4" (6) undercut with added 20 gauge sleeve, width and height are approximately actual.

Optional Construction:

Auxiliary Switch

Add to Actuator (recommended)

Add to Damper (STO/R)

Momentary Test Switch

DTO/R Dual Thermostat Override w/ Dual Position Indicator Switches

Temp: 165°/250° 165°/350° 212°/350°

Factory Sleeve:

Optional Length: _____ (Std. 16" [406])

Gauge: 20 (1.0) 18 (1.2) 16 (1.5) 14 (2.0) 10 (3.5)

Framed Retaining Angles 16ga. x 1-1/2" x 1-1/2" (1.5 x 38 x 38)

Single Side Dual Side

Remote Control Box

RCB-1 RCB-2 RCB-3

Smoke Detector

Factory Mounted Shipped Loose

Actuators (Refer to UL Damper Actuator Reference Chart)

Type: Electric: Model # _____ Pneumatic: Model # _____

Location: Right External (Std) Left External Internal

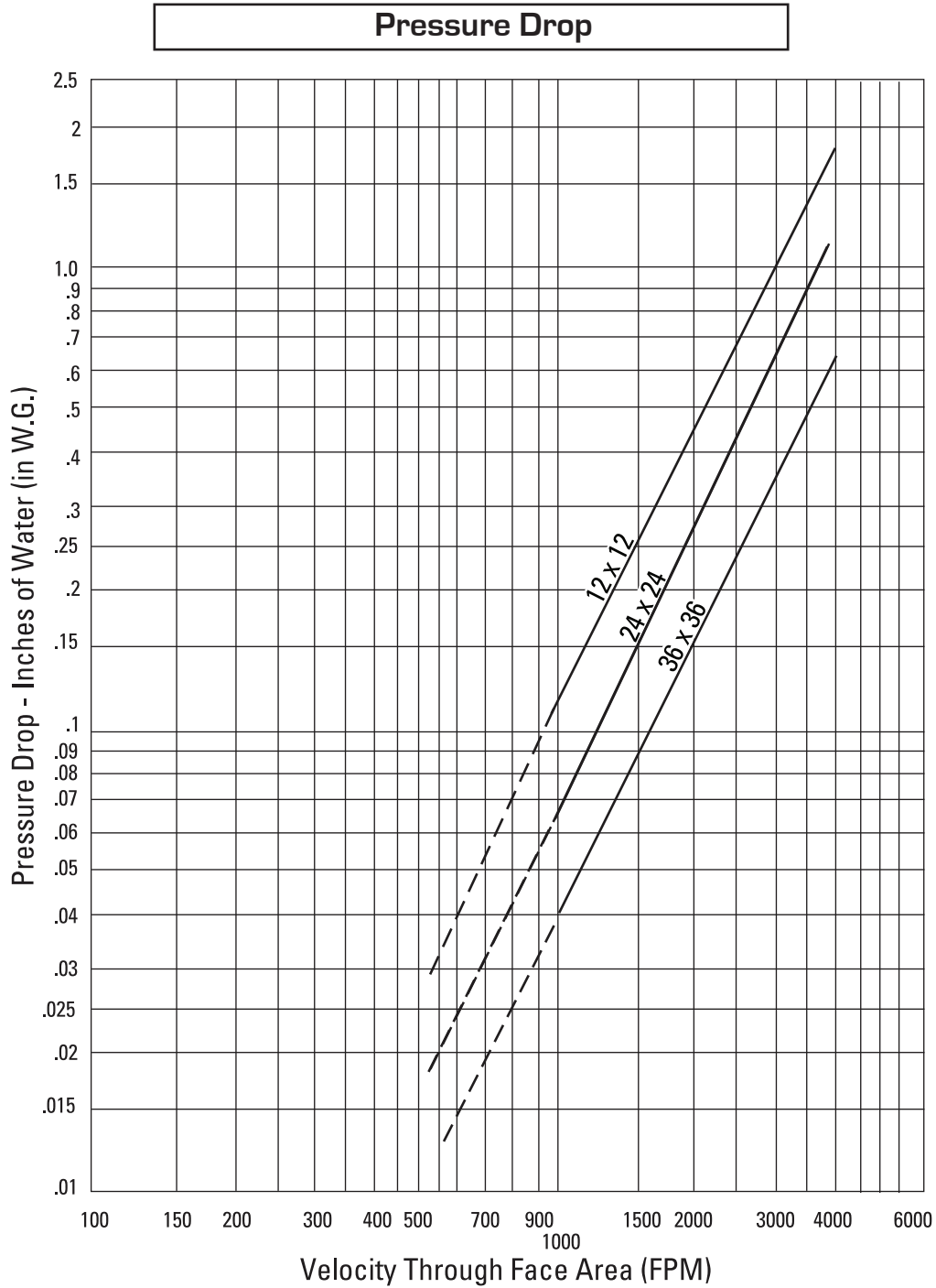

- To determine pressure drop:**
1. Locate the applicable face velocity on the bottom of the chart.
 2. Move up the chart to the most appropriate size damper line.
 3. From the intersection point, move left to determine the pressure drop.

AMCA Figure 5.3 - Ducted Inlet and Outlet

Pressure drop testing was performed by an independent laboratory to the AMCA Standard 500-D, Fig. 5.3 (ductwork upstream and downstream).

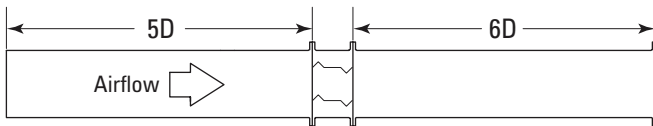

Actuator Requirements:

UL555S requires that all leakage rated dampers be provided with factory mounted actuators. Available actuators vary by damper size and velocity, pressure and temperature ratings. Consult Motor/Actuator sheet for UL Products for current offering.

Multiple section damper assemblies may require multiple actuators. In this case, all electric actuators will be factory wired to a single heat-responsive device. *The default heat-responsive device is a resettable thermostat that interrupts power to the actuator allowing for controlled closure.*

If pneumatic actuators are employed, all will be plumbed to a common PFV (Pneumatic Fusible Valve). The PFV is used in conjunction with a restrictor valve to also provide controlled closure.

Sleeve Requirements:

Standard sleeve depth is 16" (406), which is appropriate for use with up to a 5" deep (127) wall/floor and 2-sided mounting angle installation. (See Detail to the right).

When the actuator is externally mounted and the wall/floor thickness exceeds 5" (127), **add 1" (25) for each additional inch of wall thickness** to ensure sleeve fully penetrates the wall/floor. Each additional 1" (25) added will be added to the non-actuator side.

As a standard, the actuator is externally installed on the lower right-hand half of the damper when viewed from the jackshaft side. **The damper may be installed/rotated 180°** such that the actuator will be located on the upper left. The top of the damper is either side of the frame as long as the blades are running horizontal.

Damper is not approved for installation with the blades running vertically.

The entire damper frame does not have to be installed in the plane of the wall/floor. The requirement is that the blade closure line (the center line of the 5" (127) damper frame) must be within the plane of the fire-rated wall/floor.

Typical Sleeve Lengths

Wall Thickness	Min. Sleeve Length
5" (127)	16" (406)
8" (203)	20" (508)
12" (305)	24" (610)
16" (406)	28" (711)

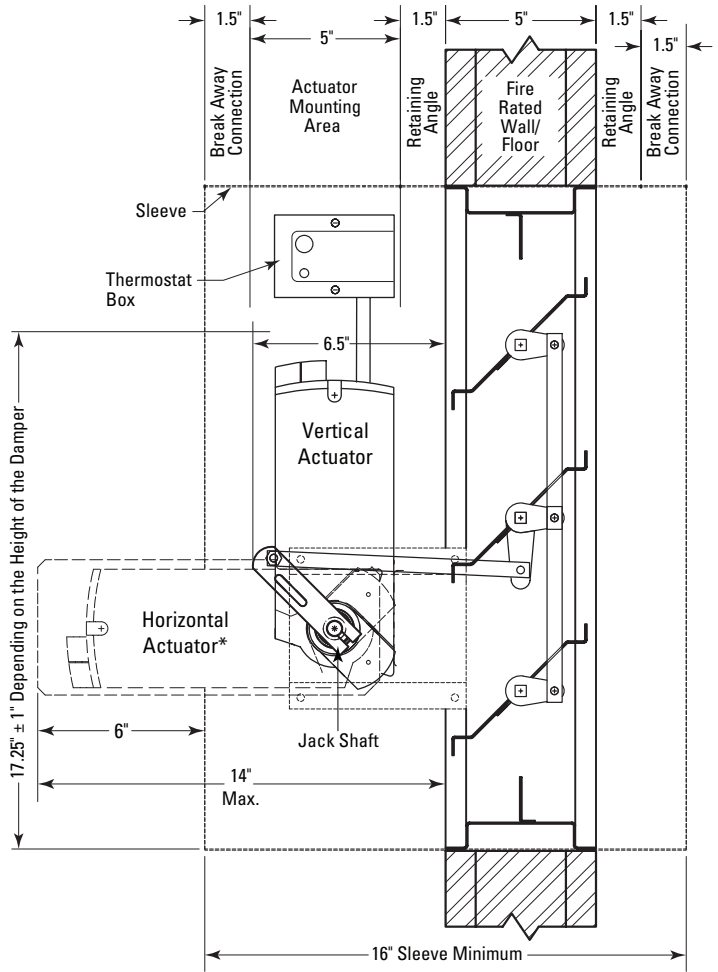

*Horizontal Actuators can be provided as "low profile" option and will be provided on a standoff to allow for duct connections. Thermostat Box location will vary, contact factory for exact location if needed.

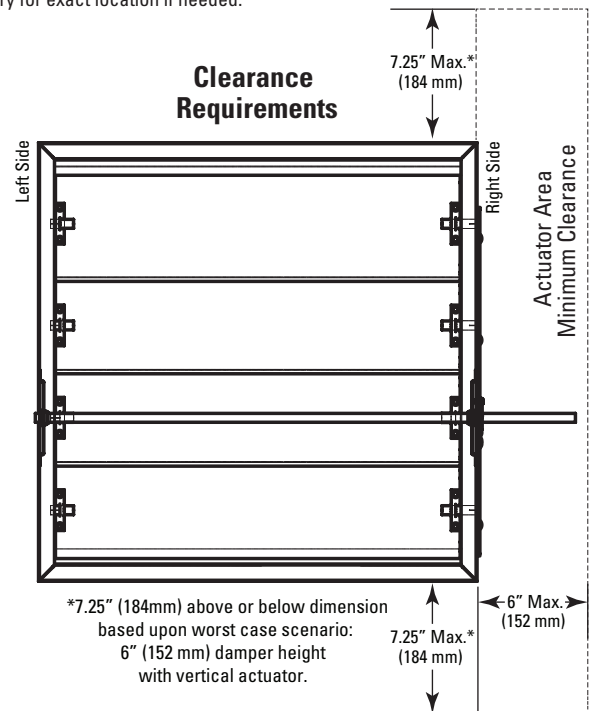

*7.25" (184mm) above or below dimension based upon worst case scenario: 6" (152 mm) damper height with vertical actuator.

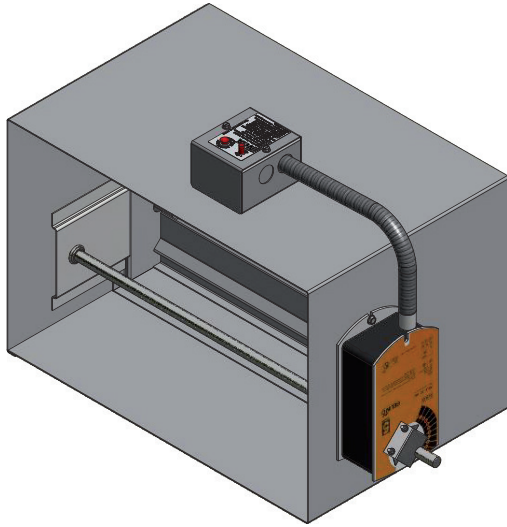

Standard Sleeve configuration where sleeve is added to damper. Damper size will be 1/4" (6) under ordered dimensions; sleeve dimension will be roughly ordered dimensions.

Flanges: An optional 3/4" (19) flanged sleeve is available for grille mounting (see Page 6, Figure 4 of the Combination Fire/Smoke Damper IOM).

Note: If actuator is to be externally mounted, the flange(s) will need to be field installed.

Duct Connections/Sleeve Transitions:

Minimum Damper height is 6" (152). If smaller duct heights are required, transition will be supplied as shown in the detail FSD-3V-212.

- **Minimum duct height for is 4" (102).**

Square to Round transitions attached on both ends of the damper sleeve (Model FSD-3V-212). Product is ordered on duct Diameter; damper will be fabricated 2" (51) larger in width and height. Collar extends 1.25" (32) beyond the sleeve length.

- **Minimum 4" (102) diameter, Maximum 94" (2388) diameter for Vertical and for Horizontal mount.**

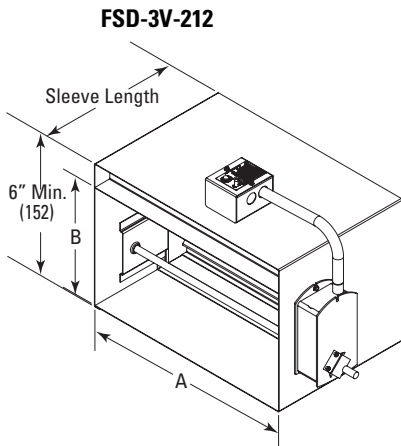

A = Duct Width
B = Duct Height

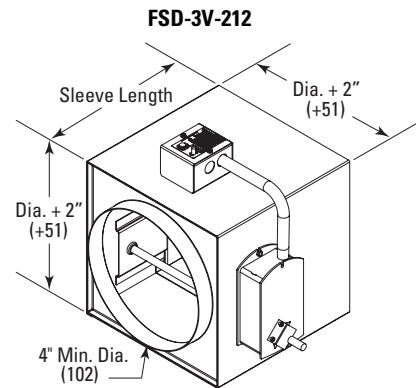

Rectangular to Oval (Model FSD-3V-212) or Square/Rectangular to Square/Rectangular (Model FSD-3V-212) transitions attached on both ends of the damper sleeve. Product is ordered on width and height of duct connection required; damper will be fabricated 2" (51) larger in width and height. Collar extends 1.25" (32) beyond the sleeve length.

- **Minimum 4" w x 4" h (102 x 102), Maximum 106" w x 94" h (2692 x 2388) for Vertical mount and 70" w x 94" h (1778 x 2388) for Horizontal mount.**

