

Pressure Relief Dampers



CVS 
DAMPER SERIES

Reference:

Client:

Project:

Consultant:

Location:

Contractor:

Date:

Submitted by:



Your Reliable HVAC Partner

Model CB-600 Series
Backdraft/Pressure Relief Dampers

Application:

The CVS Backdraft Dampers (also called gravity dampers) CB-600 Series allow airflow in one direction and prevent reverse airflow for use in exhaust or intake HVAC systems suitable for wall mounted applications.

Backdraft dampers can either be operated by gravity (where pressure or velocity opens and gravitational force closes the damper). These models can be provided with counter balance weights in order to assist or retard the opening of the damper.

Standard Construction:

	Standard	Optional
Frame Material	20 gauge galvanized steel	Galvanized steel and aluminum with different thicknesses
Frame Depth	75mm	-----
Flange	30mm	Consult factory for other sizes
Blade Material and Type	24 gauge galvanized steel	Galvanized steel and aluminum with different thicknesses
Blade Seal	Rubber Foam	Neoprene
Dimensions	Actual - 6mm	Actual
Axle Material	Plated steel	-----
Axle Bearings	Synthetic	-----
Finishes	Mill Finish	Powder Coated
Counter Weight	None (Backdraft)	Counter Weight (PRD)

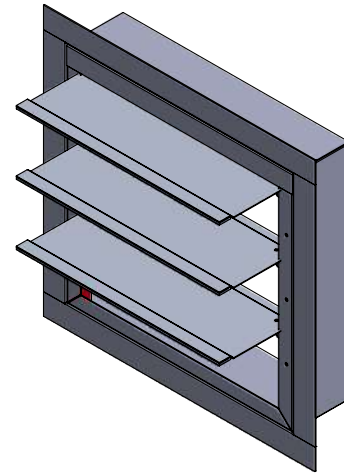

Front View

Side View

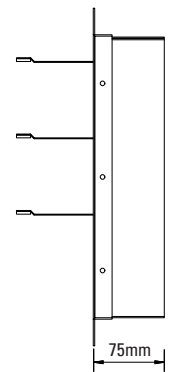
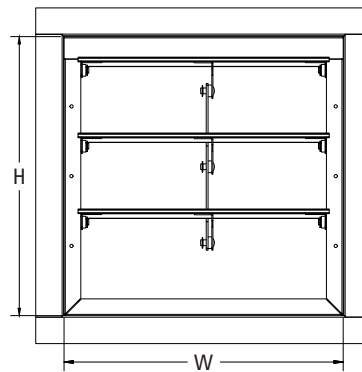

Minimum & Maximum Sizes:

Model	Minimum Single Section	Maximum Single Section	Maximum Multi Section
CB-600 Series	6" x 6" (152 x 152)	40" x 40" (1016 x 1016)	Unlimited Size (Please consult factory)

All dimensions shown in inches, parentheses () indicate millimeters.

Optional Construction:

Insect Mesh

Bird Mesh

Counter Weight Options for Pressure Relief Dampers:

Counter Weight at Blade's Front Side

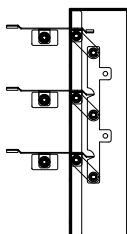

Counter Weight at Blade's Back Side

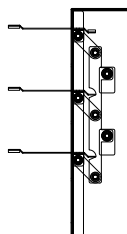

Top View

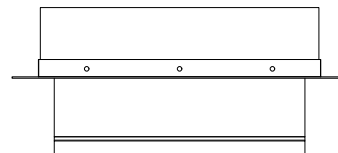

Section View

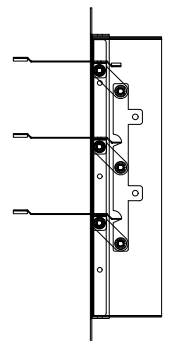

As part of our continuous improvement program, we reserve the right to make further improvements without notice.

Submittal

Reference:

Client:

Project:

Consultant:

Location:

Contractor:

Date:

Submitted by:



Your Reliable HVAC Partner

Model CB-601 Series
Backdraft/Pressure Relief Dampers

Application:

The CVS Backdraft Dampers (also called gravity dampers) CB-601 Series allow airflow in one direction and prevent reverse airflow for use in exhaust or intake HVAC systems suitable for duct mounted applications. Backdraft dampers can either be operated by gravity (where pressure or velocity opens and gravitational force closes the damper). These models can be provided with counter balance weights in order to assist or retard the opening of the damper.

Standard Construction:

	Standard	Optional
Frame Material	20 gauge galvanized steel	Galvanized steel and aluminum with different thickness and flange sizes
Frame Depth	127mm	-----
Blade Material and Type	24 gauge galvanized steel	Galvanized steel and aluminum with different thicknesses
Blade Seal	Rubber Foam	Neoprene
Dimensions	Actual - 6mm	Actual
Axle Material	Plated steel	-----
Axle Bearings	Nylon	Brass
Finishes	Mill Finish	Powder Coated
Counter Weight	None (Backdraft)	Counter Weight (PRD)

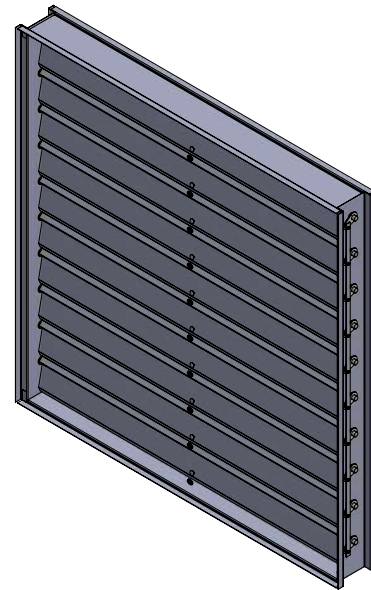

Minimum & Maximum Sizes:

Model	Minimum Single Section	Maximum Single Section	Maximum Multi Section
CB-601 Series	6" x 6" (152 x 152)	40" x 40" (1016 x 1016)	Unlimited Size (Please consult factory)

All dimensions shown in inches, parentheses () indicate millimeters.

Optional Construction:

Insect Mesh

Bird Mesh

Counter Weight Options for Pressure Relief Dampers:

Counter Balancing - Externally

Counter Balancing - Internally

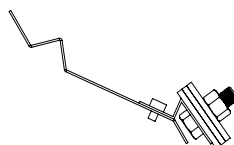
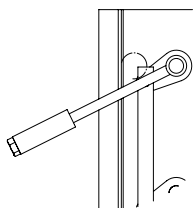

Front View

Side View

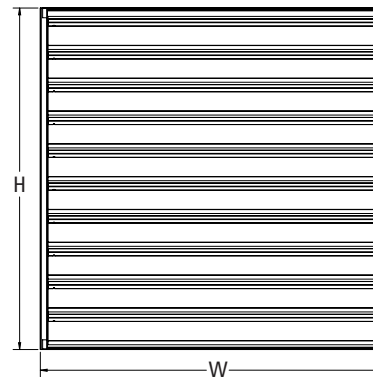

Top View



As part of our continuous improvement program, we reserve the right to make further improvements without notice.

Submittal

PERFORMANCE DATA

Air Performance testing has been performed in accordance with Test Method as per latest version of ANSI/AMCA Standard 500-D, Figure 5.4 for Air Leakage and Figure 5.5 for Pressure Drop. Air leakage is based on operation between 0°C- 49°C(32°F - 120°F).

PRESSURE DROP GRAPH - 24" x 24"

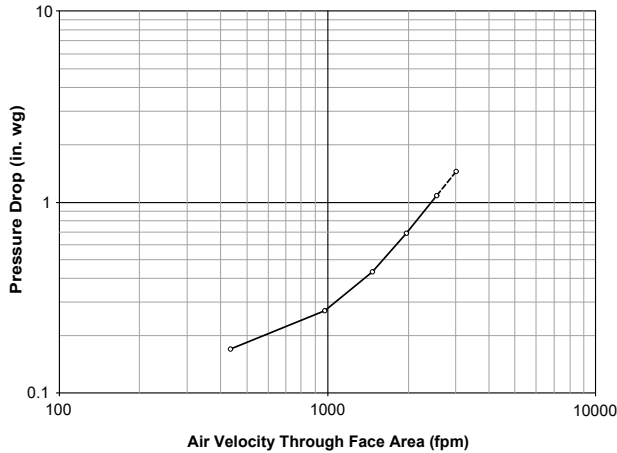

PRESSURE DROP OF DAMPER

24" x 24" - (610 x 610)	
Intake	
Velocity	Pressure Drop
(fpm)	(in. w.g.)
2557	1.082
1965	0.683
1472	0.432
979	0.27
434	0.17

AIR LEAKAGE GRAPH

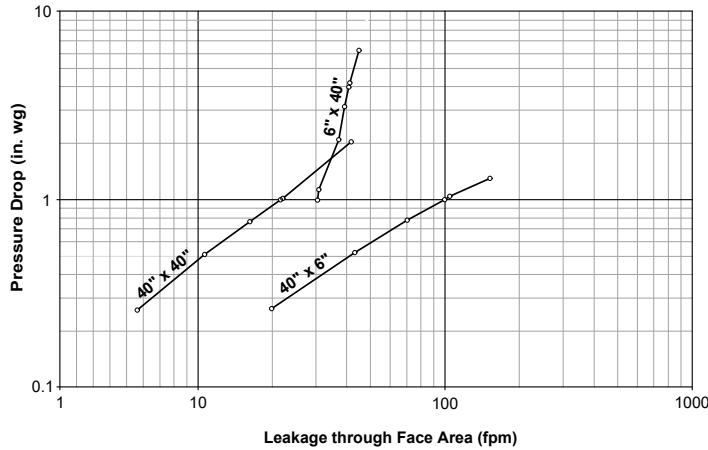

Test Figure 5.5 - Test Damper Setup with Inlet Chamber

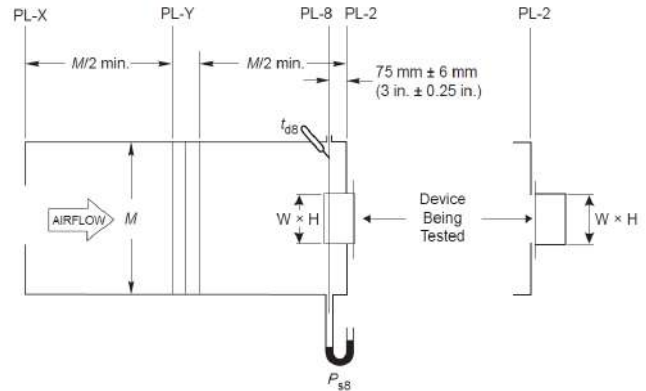

Test Figure 5.4 - Test Damper Setup with Outlet Chamber

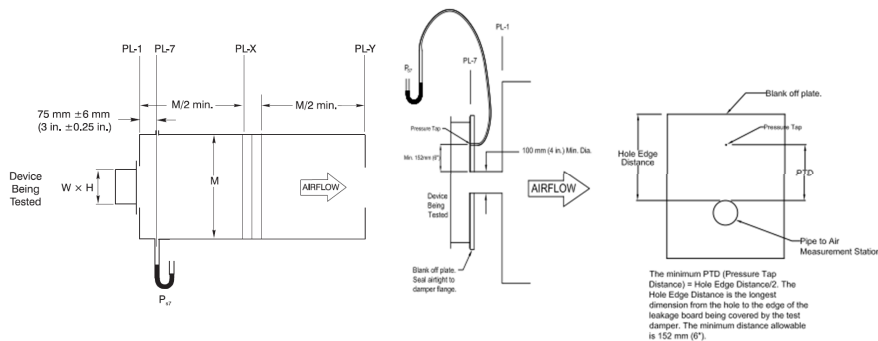

CVSA
DAMPER SERIES



SUGGESTED SPECIFICATION:

Central Ventilation Systems certifies that the Backdraft Damper Models CB Series as shown herein are licensed to bear the AMCA Seal. The ratings shown are based on tests and procedures performed in accordance with AMCA Publication 511 and comply with the requirements of the AMCA Certified Ratings Programs.

The AMCA Certified Ratings Seal applies to air performance and air leakage ratings only.

Cat ID: CB Series	Rev. No.: 00	Date: June 2023	Page: 4/5
----------------------	-----------------	--------------------	--------------



**HEAVY DUTY
 BACKDRAFT DAMPER**

Application and Design

The **HCB-700** Series is a vertically or horizontally mounted backdraft damper that is designed to allow vertical or horizontal airflow and prevent reverse airflow.

Ratings:

- Pressure:** 4 in. w.g. - differential pressure
- Velocity:** 4000 fpm
- Temperature:** 180° F

Standard Construction:

- Frame:** .081 Extruded Aluminum 4-1/2" deep
- Blade:** 6060T5 Extruded Aluminum .125 thickness
- Linkage:** Zinc plated concealed
- Axles:** 1/2" diameter cast zinc & steel
- Blade Seals:** PVC (180°F)
- Bearings:** Bronze Oilite

Size Limitations:

- Minimum Size:** 6" w x 6" h
- Maximum Single Section:** 48" w x 48" h
- Maximum Double Section:** 96" w x 96" h

Options and Accessories:

- .125 Extruded Aluminum Frame (box frame)
- 1-1/2" flanged frame- .081" extruded aluminum (no side plate)
- In airstream counterbalanced weights (no side plate)
- Epoxy coated (powder coated @ 415°F)
- 450°F Silicone blade seals
- Side Plate (20ga. galvanized steel)

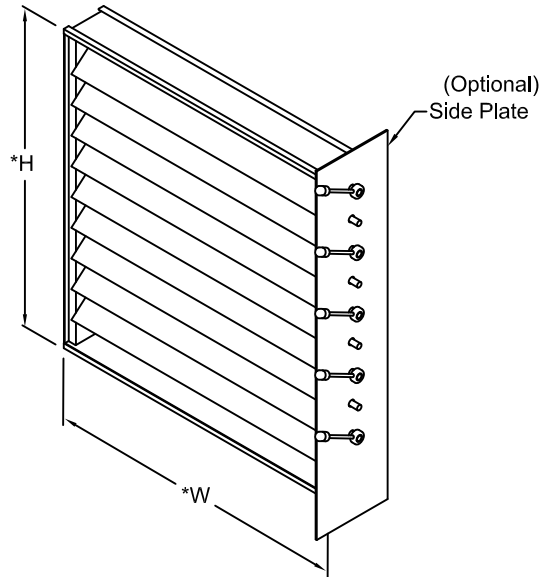

*W & H dimensions furnished approximately 1/4" undersize.

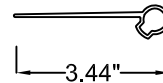

Blade Detail

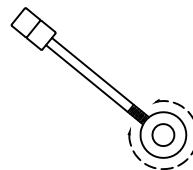

Precision Counter Balanced; both by rotation in hub or slide weight up or down the rod in addition to removal or adding weights.

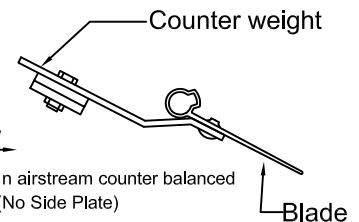

AIR FLOW

Optional: In airstream counter balanced (No Side Plate)

Vertical mount with horizontal airflow shown



Optional: In airstream counter balanced (No Side Plate)

Quantity	Size		Other Options
	'W' Width	'H' Height	

Job Name:

Location:

Architect:

Engineer:

Contractor:

MODEL HCB-700 (4000 FPM)

DAMPER PERFORMANCE

DAMPER WIDTH	MAXIMUM BACK PRESSURE	MAXIMUM SYSTEM VELOCITY	LEAKAGE*		BLADES START TO OPEN	BLADES FULLY OPEN
			Percent of Max. Flow	CFM/ Sq. Ft.		
48" (1219)	4.0" w.g.	4000 FPM	.61	15		
36" (914)	8.0" w.g.	4000 FPM	.6	15	** .01" w.g.	** .05" w.g.
24" (610)	12.0" w.g.	4000 FPM	.72	18		
12" (305)	16.0" w.g.	4000 FPM	1	24		

*Leakage information based on pressure differential of 1" w.g. tested per AMCA Std. 500.

**set at least resistant to open

DAMPER PRESSURE DROP
(24" X 24")

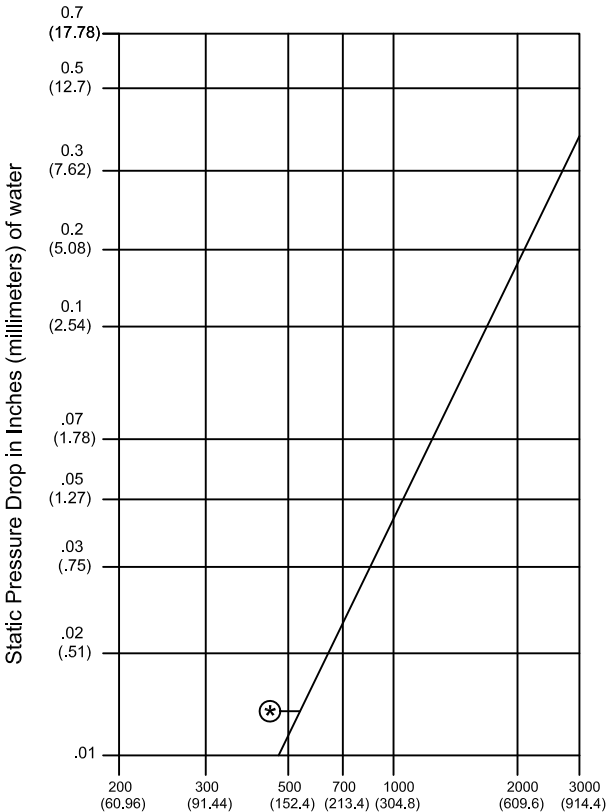

HCB-700 AIR FLOW ARRANGEMENTS

Standard weights at jamb
(assist to CLOSE)

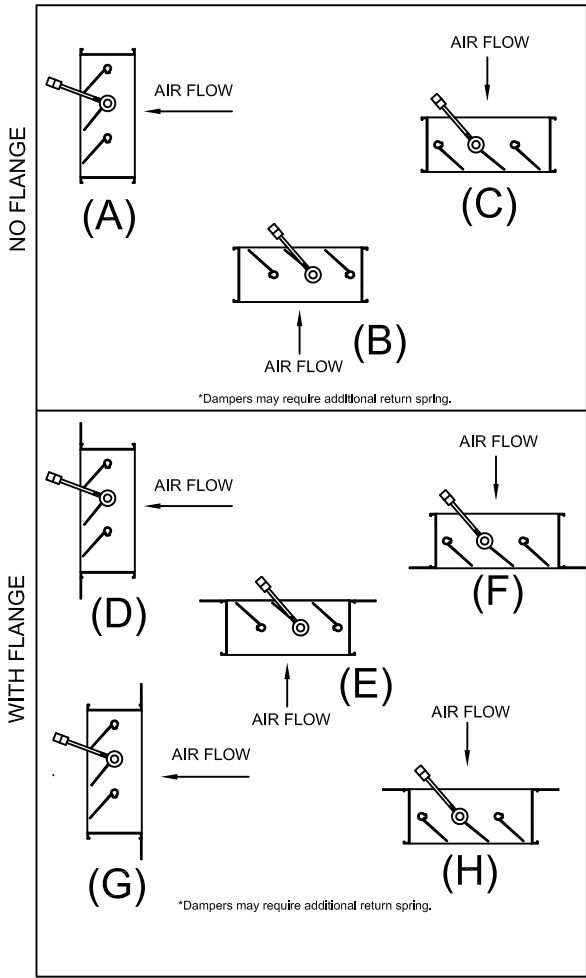



**HEAVY DUTY
 BACKDRAFT DAMPER**

Application and Design

The **HCB-750** Series is a vertically or horizontally mounted backdraft damper that is designed to allow vertical or horizontal airflow and prevent reverse airflow.

Ratings:

- Pressure:** 4 in. w.g. - differential pressure
- Velocity:** 4000 fpm
- Temperature:** 180° F

Standard Construction:

- Frame:** 16ga. Galvanized Steel
- Blade:** 16ga. Galvanized Steel V-Blade
- Linkage:** Zinc plated concealed
- Axles:** 1/2" diameter cast zinc & steel
- Bearings:** Bronze Oilite
- Blade Seals:** PVC (180° F)

Size Limitations:

- Minimum Size:** 6" w x 6" h
- Maximum Single Section:** 48" w x 48" h
- Maximum Double Section:** 96" w x 96" h

Options and Accessories:

- Heavier gauge Steel construction
- Custom flange
- Side Plate (20ga. galvanized steel)
- All #304 Stainless Steel construction
- All #316 Stainless Steel construction
- In airstream counterbalanced weights
- Epoxy coated (powder coated @ 415°F)
- 450°F silicone blade seals

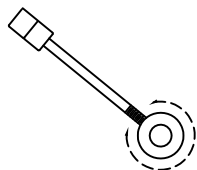
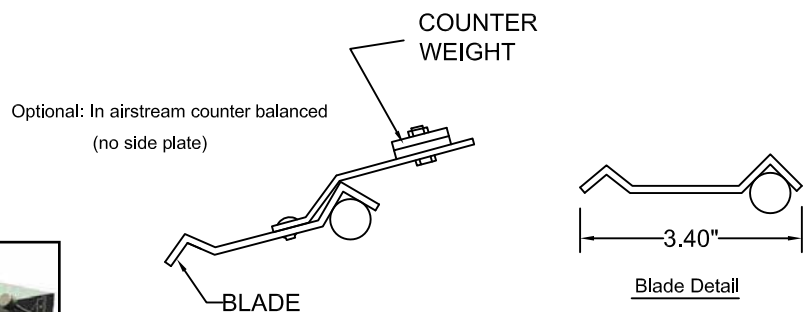
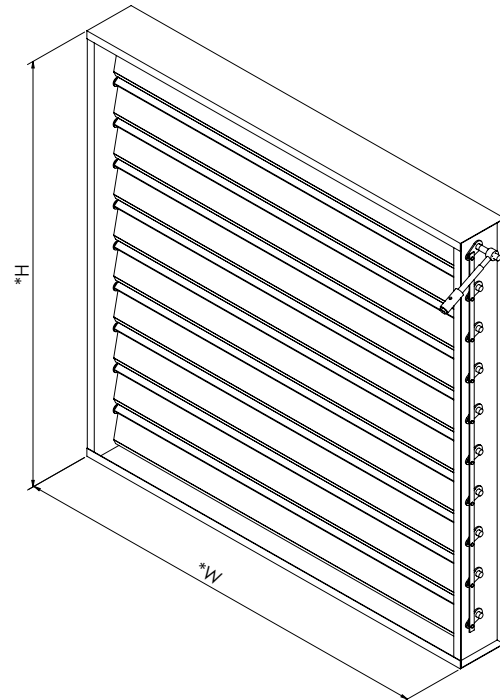

Precision Counter Balanced; both by rotation in hub or slide weight up or down the rod in addition to removal or adding weights.



Quantity	Size		Other Options
	'W' Width	'H' Height	

Job Name:

Location:

Architect:

Engineer:

Contractor:

MODEL HCB-750 (4000 FPM)

DAMPER PERFORMANCE

DAMPER WIDTH	MAXIMUM BACK PRESSURE	MAXIMUM SYSTEM VELOCITY	LEAKAGE*		BLADES START TO OPEN	BLADES FULLY OPEN
			Percent of Max. Flow	CFM/ Sq. Ft.		
48" (1219)	4.0" w.g.	4000 FPM	.61	15		
36" (914)	8.0" w.g.	4000 FPM	.6	15	** .01" w.g.	** .05" w.g.
24" (610)	12.0" w.g.	4000 FPM	.72	18		
12" (305)	16.0" w.g.	4000 FPM	1	24		

*Leakage information based on pressure differential of 1" w.g. tested per AMCA Std. 500.

**set at least resistant to open

HCB-750 AIR FLOW ARRANGEMENTS

Standard counter weights at jamb
(assist to CLOSE)

DAMPER PRESSURE DROP
(24" X 24")

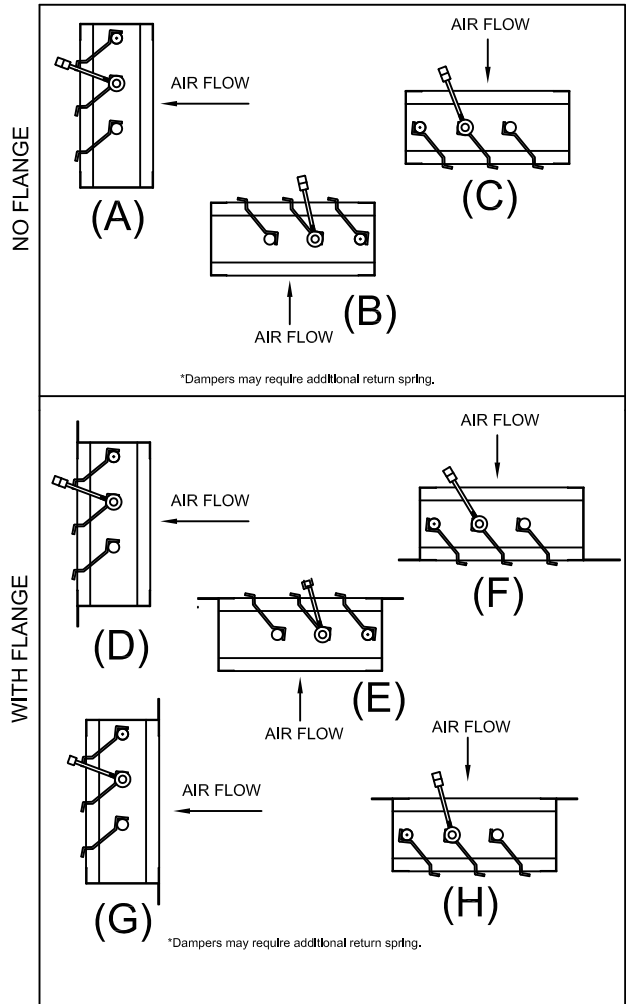
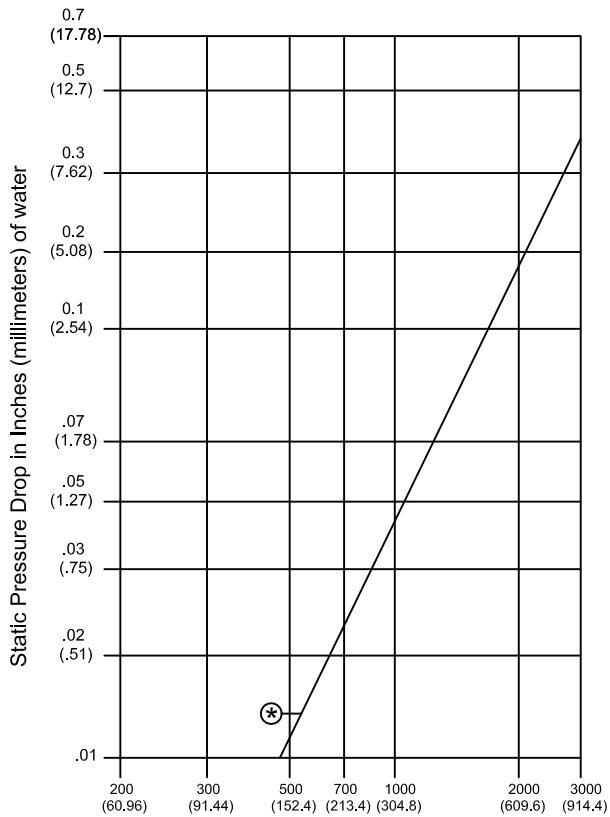



BACKDRAFT DAMPERS

STATIC PRESSURE RELIEF DAMPER

Application and Design

The Static Pressure Relief Damper, Model RCD, is a single blade steel damper with counterbalanced weighted arm. The RCD is used as a relief damper to by-pass excess air when various zone dampers close down. The RCD can be adjusted by moving the weight up and down the damper arm and also by off-setting the arm to the damper blade. The RCD is recommended for use on systems with less than 0.3" static pressure.

Additional weights can be ordered for optimum control of the damper.



MODEL RCD

Construction:

Frame: .081" Extruded Aluminum

Blade: .090" Aluminum

SIZES AVAILABLE:

12 x 8	1000 cfm	20 x 8	1600 cfm
12 x 10	1200 cfm	20 x 10	2000 cfm
12 x 12	1400 cfm	20 x 12	3000 cfm

CONSULT FACTORY FOR OTHER SIZES

Job Name:

Location:

Architect:

Engineer:

Contractor:

MODEL RCD

Product Range

- ▶ Fire-Resisting Ductwork (BS & EN)
- ▶ Fire-rated Insulation (ASTM & UL)
- ▶ Sound Attenuators (ASTM & BS)
- ▶ VAV Boxes (AHRI)
- ▶ Life Safety Dampers (UL)
- ▶ Control Dampers (AMCA & BS)
- ▶ Access Doors (BS & EN)
- ▶ Louvers (AMCA)
- ▶ Smoke Exhaust, Building, Car Park & Tunnel Ventilation Fans (AMCA & EN)
- ▶ Domestic and Industrial Ventilation Fans
- ▶ AHU, FAHU, FCU, RTU, ERV & Ecology Units (Eurovent, TUV & AHRI)
- ▶ Electrostatic Precipitators (ESPs) & UL Listed Air Filters (UL)

Our Brands



Non-Coated Fire-Resisting Ductwork & Life Safety Dampers



Smoke Exhaust, Car Park & Tunnel Ventilation



Control Dampers, Louvers, Sound Attenuators & VAV Boxes



Fire-rated Insulation



Coated Fire-Resisting Ductwork



General Ventilation



AHU, FCU, RTU, ERV & Ecology Units

U.A.E

Industrial Area 2,
Al Wasit Road,
Sharjah, UAE

K.S.A

Dammam 2nd
Industrial City,
Dammam 31952,
K.S.A

Egypt

Al Minya Industrial Zone,
Al Minya Governorate
2427606, Egypt

Qatar

Street 9 Industrial Area,
Doha, Qatar



sales@cvshvac.com



www.cvshvac.com